

Orbital riveting technology

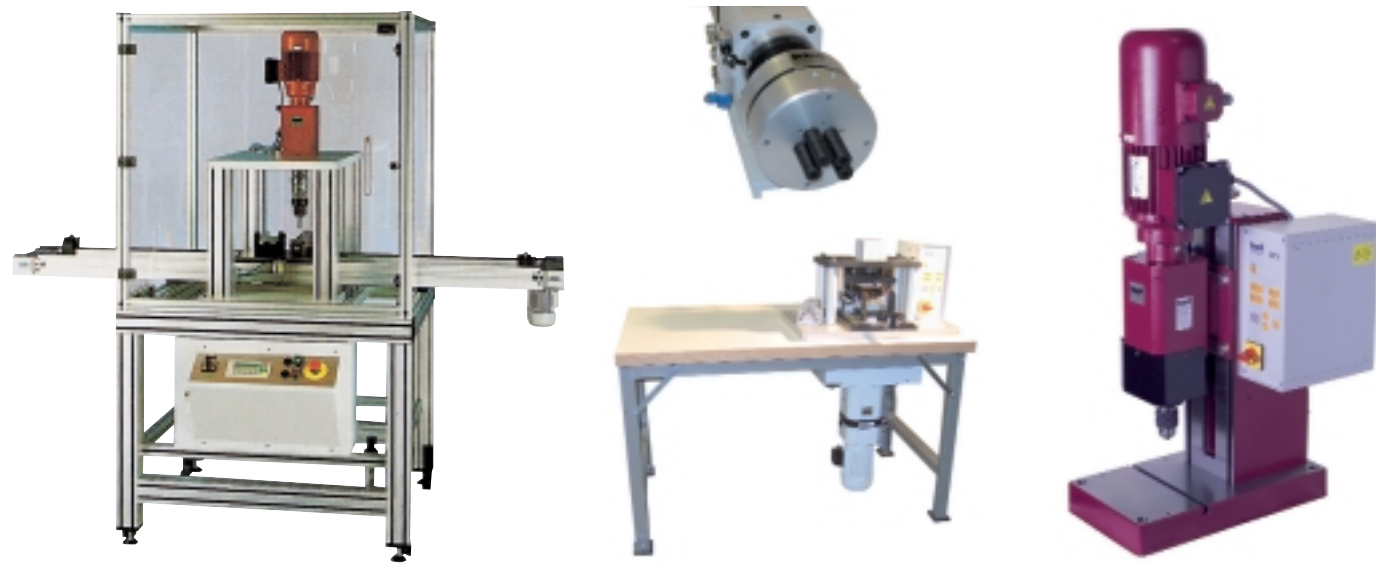

Conveyor technology – Flexible assembly systems – Workpiece carriers – Transport systems



Presses and Rotary indexing tables

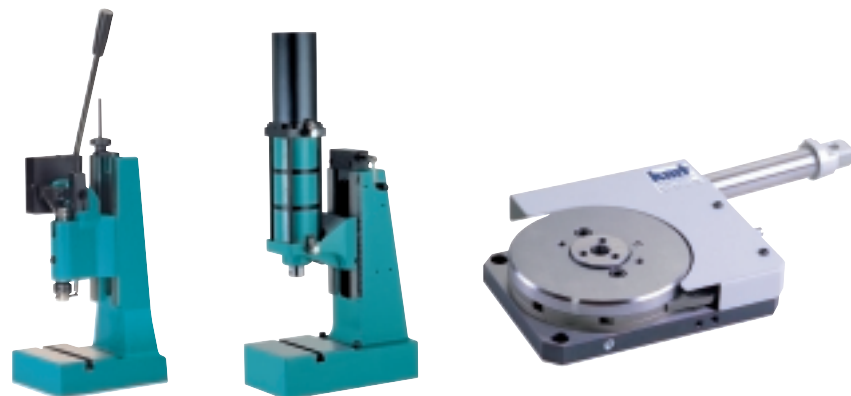

Orbital riveters

- Assembly systems
- Small conveyors
- Rotary indexing tables
- Multiple spindle heads

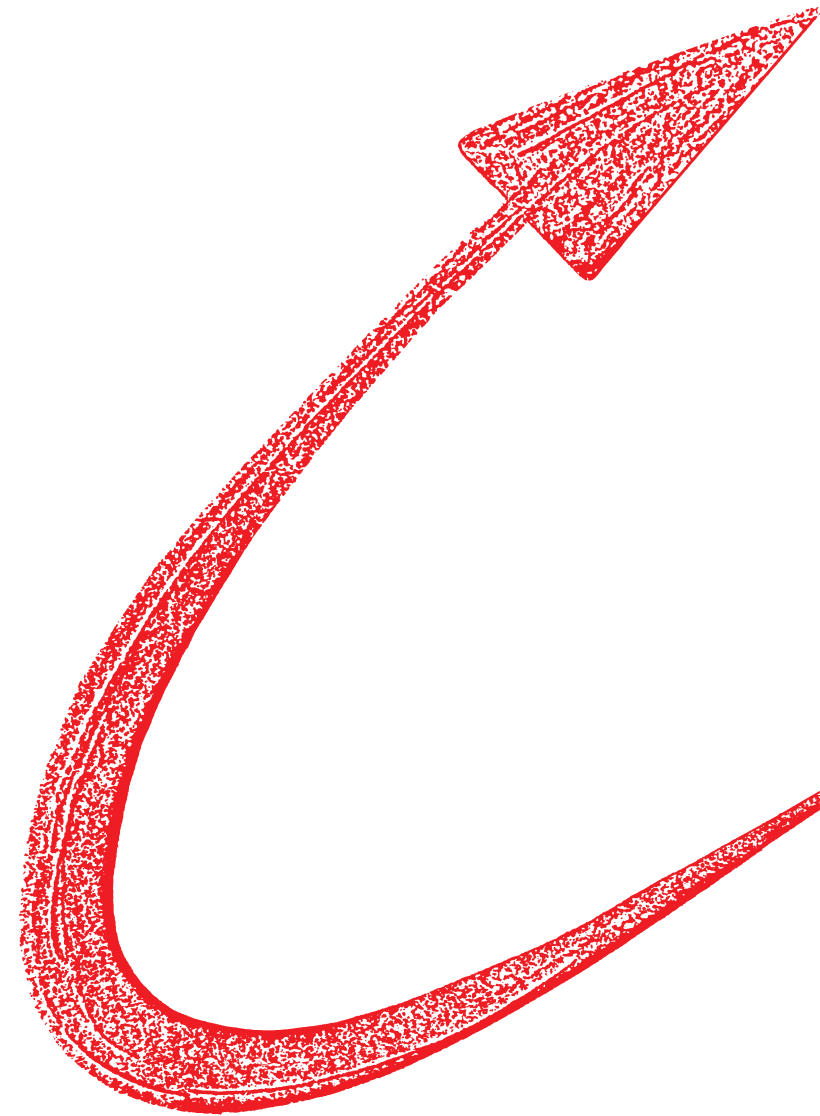

Connection Technology
Orbital Riveters

- Your specialist for reliable connections

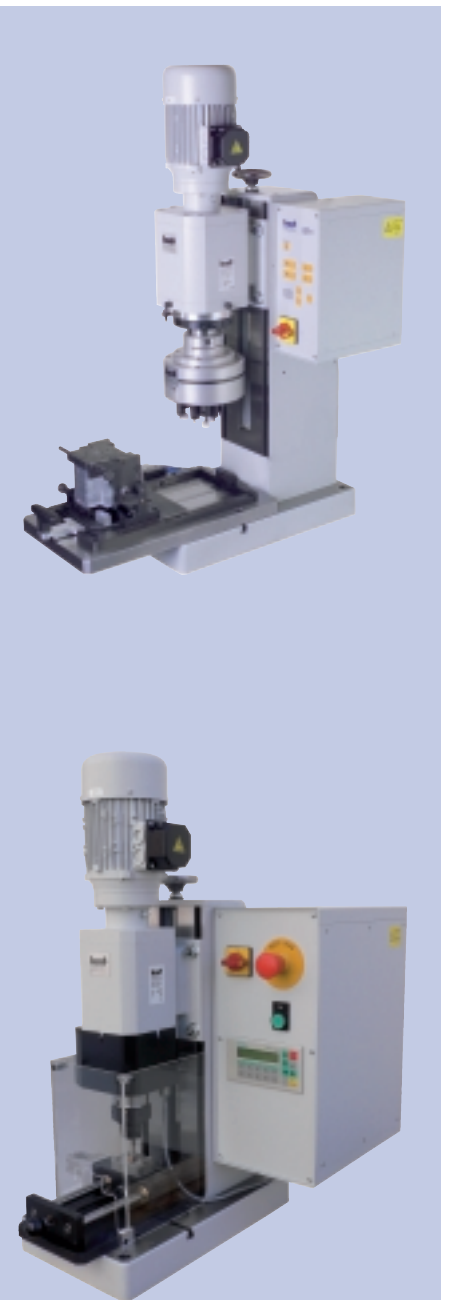



Welcome.

For many years now, we have been developing innovative and successful solutions for our partners in the assembly and automation technology sector.

Uncompromising support, sound knowledge, unsurpassable quality and a self-confident approach in addressing challenges are the key to our success.

Assisted by a well-trying network of specialists, we offer holistic solutions from one source.

This makes us both flexible and cost-efficient.

Profit from our experience.

Your success is our mission.

We thrive on new and interesting challenges.

Marc Heiter
Chief Executive Officer



Areas of Application

Controls

Control ST 1 for standard, uncomplicated riveting

- main switch with emergency-off
- pilot lamp, automatic mode, fault indicator
- preselection switch - rivet force, step I and II
- preselection switch - automatic / manual mode
- preselection switch - rivet/stroke time
- Actuation of riveting process
 - foot-operated switch
- optional:
 - 2 hand start
 - external actuation
 - sliding device

Control ST 2 for high-quality automatic and manual riveting

- simple menu-guided operation of all functions via display
- positioning in 0.01 mm or 0.01 bar increments
- up to 6 mm stroke range
(depending on measuring system (e.g. laser) 10 mm also possible)
- 1 - 10 bar pressure range

Same features as ST 1 plus:

- stroke monitoring with measured value display
- or alternative pressure monitoring with measured value display
- part counter
- service menu
- installed software – pressure or displacement

Control ST 3 for top quality-monitored automatic and manual riveting

- with automatic realization of rivet parameters: unfinished rivet length, force/displacement curve
- identification system in work stroke
- automatic positioning and monitoring of rivet displacement
- compressive force monitoring during forming

Same features as ST 2 plus:

- software pressure and stroke monitoring
- 3x analogous processing
- storage of up to 10 different riveting programs on request

optional

- parallel interface for data output
- external actuation via I/O or BUS
- serial RS 485 interface
- storage of more than 10 different riveting programs for different parts
- data remote maintenance via modem
- Profibus
- rivet protrusion measurement via sensor
- graphics representation of rivet parameters
- SPC



Rivet machines with sliding device and ST 2 control

Your specialist for
reliable connections



Orbital Riveters



Your advantages

- for high-speed riveting, extra fast feed, spindle speed 1360 rpm or 2800 rpm on request
- for use as a shaft riveting unit with centering collar or as standard unit (rear fixation)
- not restricted to a specific position, can also be used overhead
- stepless force adjustment via pressure setting
- standard version with end position damping and feed speed setting
- maintenance-free
- with stroke limiting ring (stepless return stroke setting)
- standard stroke 40 mm optional 80 mm or 100 mm, other possibilities on request
- for 2 rivet processes:
 - rotational or radial orbital riveting units also used for crimping and curling

Modular construction ✓

Thanks to their modular construction, all mechanical and control-related components can be combined as desired.

High flexibility ✓

Thanks to their modular construction, our systems can be easily adapted to the requirements on hand. High flexibility is guaranteed - Modular construction permits flexible usage!

Service-friendly ✓

Easy to operate and service-friendly are just two of the standard features of our products. Speedy on-site service whenever needed goes without saying!

Quality control ✓

For monitoring production and quality assurance, the units can be equipped with our well-proven force/displacement control!!

Technical data

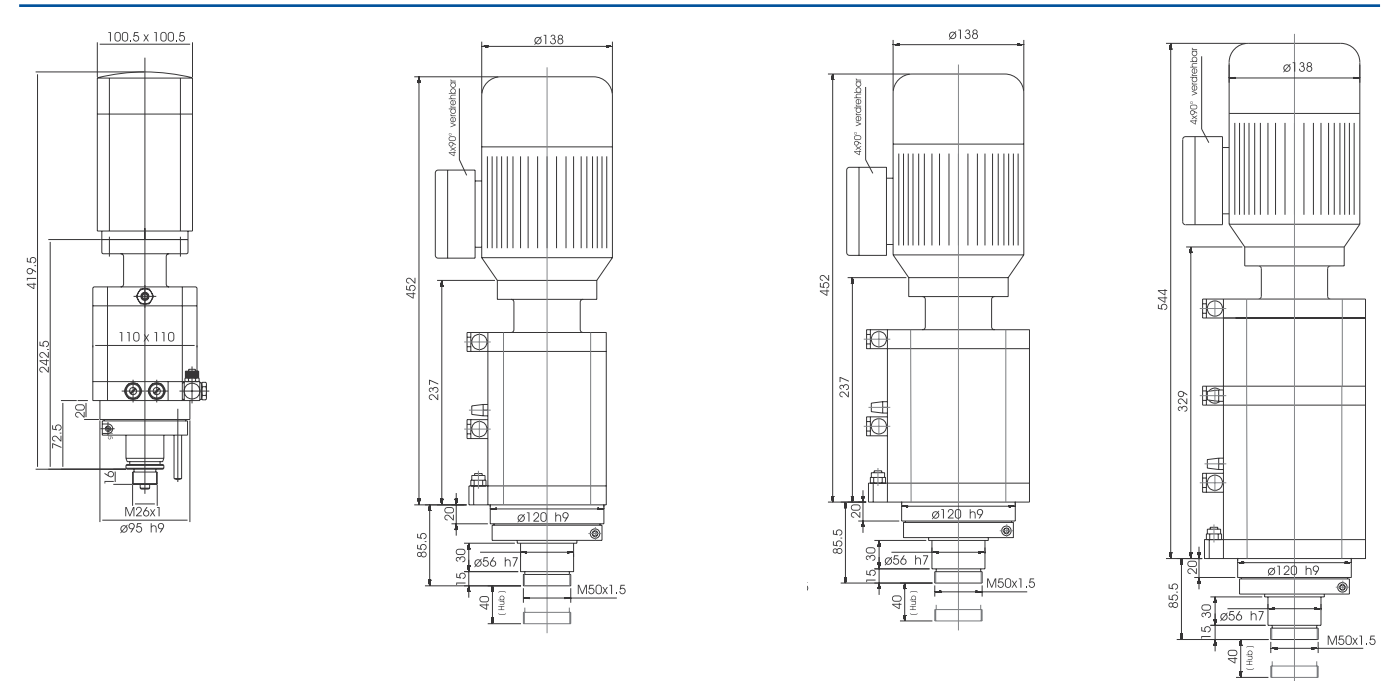

TNE 250

TNE/TNEF 750*
TNE 450

TNE/TNEF 1250*
TNE 650

TNE 2000

Data of riveting units	TNE 250	TNE/TNEF 750	TNE/TNEF 1250	TNE 2000	TNE 450	TNE 650
Riveting force at 6 bar:	Step I 2,8 kN	Step I 4,5 kN Step II 7,5 kN	Step I 6,5 kN Step II 12,5 kN	Step I 6,5 Step II 12,5 Step III 19,4	Step I 4,5 kN	Step I 6,5 kN
Weight:	13 kg	19/23 kg	23/27 kg	27 kg	19 kg	23 kg
Rivet diameter:	ST 37 = 2,5 mm	ST 37 = 7,5 mm	ST 37 = 12,5 mm	ST 37 = 16,5	ST 37 = 4,5 mm	ST 37 = 6,5 mm
Standard stroke:	50 mm	40 mm	40 mm	40 mm	100 mm	100 mm
Integrated fine adjustment:		o	o			

Electrical data						
Voltage:	400 / 230 V	400 V, 50 Hz three-phase	400 V, 50 Hz three-phase	400 V, 50 Hz three-phase	400 V, 50 Hz three-phase	400 V, 50 Hz three-phase
Current consumption:	0,72/1,25 A	1,2 A	1,2 A	1,2 A	1,2 A	1,2 A

Pneumatic data						
Minimum pressure:	2 bar	2 bar	2 bar	2 bar	2 bar	2 bar
Operating pressure:	2 - 7 bar	2 - 7 bar	2 - 7 bar	2 - 7 bar	2 - 7 bar	2 - 7 bar
Air consumption:						
Step I	ca. 2,0 l	3,57 l	6,23 l	6,23 l	5,18 l	9,17 l
Step II		5,18 l	9,17 l	9,17 l		
Step III				12,2 l		
Compressed air supply:	Maintenance unit without oiler					

Data of riveting units	TN 250	TN/TNF 750	TN/TNF 1250	TN 2000	TN 450	TN 650
Height / Width / Depth:	830/160/270	860/250/480	860/250/480	1000/300/450	860/250/480	860/250/480
Weight:	32 kg	82,5/86,5 kg	85,5/98,5 kg	135 kg	82,5 kg	85,5 kg
Adjustable in height:	o	o	o	o	o	o
Throat depth:	80 mm	100 mm	100 mm	150 mm	100 mm	100 mm
Standard colours:	Bordeaux, light grey, mignonette green					
Other RAL colours available						

* Height with integrated fine adjustment: Standard + 90 mm

** Other motor voltages on request

TNE = Orbital riveting unit

TNEF = Orbital riveting unit with integrated fine adjustment

TN = Orbital riveter comprising orbital riveting unit and base

Dimension and design details subject to change!



Rivet examples
Rivet/rivet head shapes

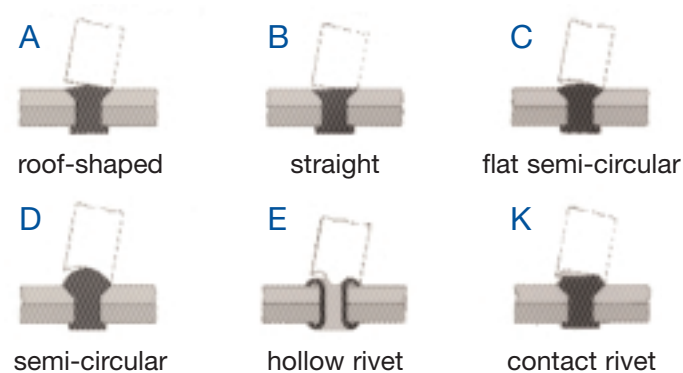

Progressive modular conception



Examples



Automobile supplier industry:

Airbag, belt tensioner, safety belt, ignition lock, steering column, steering wheel, car seat, CD and cassette drives, motor auxiliaries, convertible hood mechanics, exhaust gas regulation valve, door locks, hinges, fittings, motor bearings, cigarette lighter, instrumentation, rollers, boot and bonnet hinges, attachment systems in vehicles, exhaust pipe fittings, windscreen wipers, shifter pegs, horns, ABS motors, fuse boxes, clutches, brakes, dynamos, etc.



Lock, construction fitting and furniture industry:

Locks, hinges, window fittings, door fittings, pullouts, castors, gas fittings, handcuffs, loudspeakers, gutters, etc.



Electrical industry:

Connections, switches, sockets, relays, fuses, razors, plugs, electrical motors, automatic circuit breakers, lighting, force sensors, condensers, electrical boiler connection terminals, switch blades for high voltage. As well as a variety of other applications, e.g. for use in medical technology or optical and precision industries, etc.



Aerospace industry:

Turbine elements, security technology, undercarriage components, hydraulics, installation material, mounting elements, etc.



Sport equipment and household appliance industry:

Ski bindings, ski stoppers, sports shoes, bicycle technology, helmets, golf shoes, bicycle chains, aviation, water sport, tin openers, kitchen appliances, mixers and grain mills, gears, etc.



In our well equipped laboratory, we determine the best possible rivet connection for your components. Many rivet connections have already been manufactured and tested in our laboratory during the prototype phase of product development.

